

"FLEXORBER" by SHOCKGUARD Typical "Sog" Series Expansion - Contraction Compensator with options. 316L wetted metal plus PTFE Membrane.

Since 1979

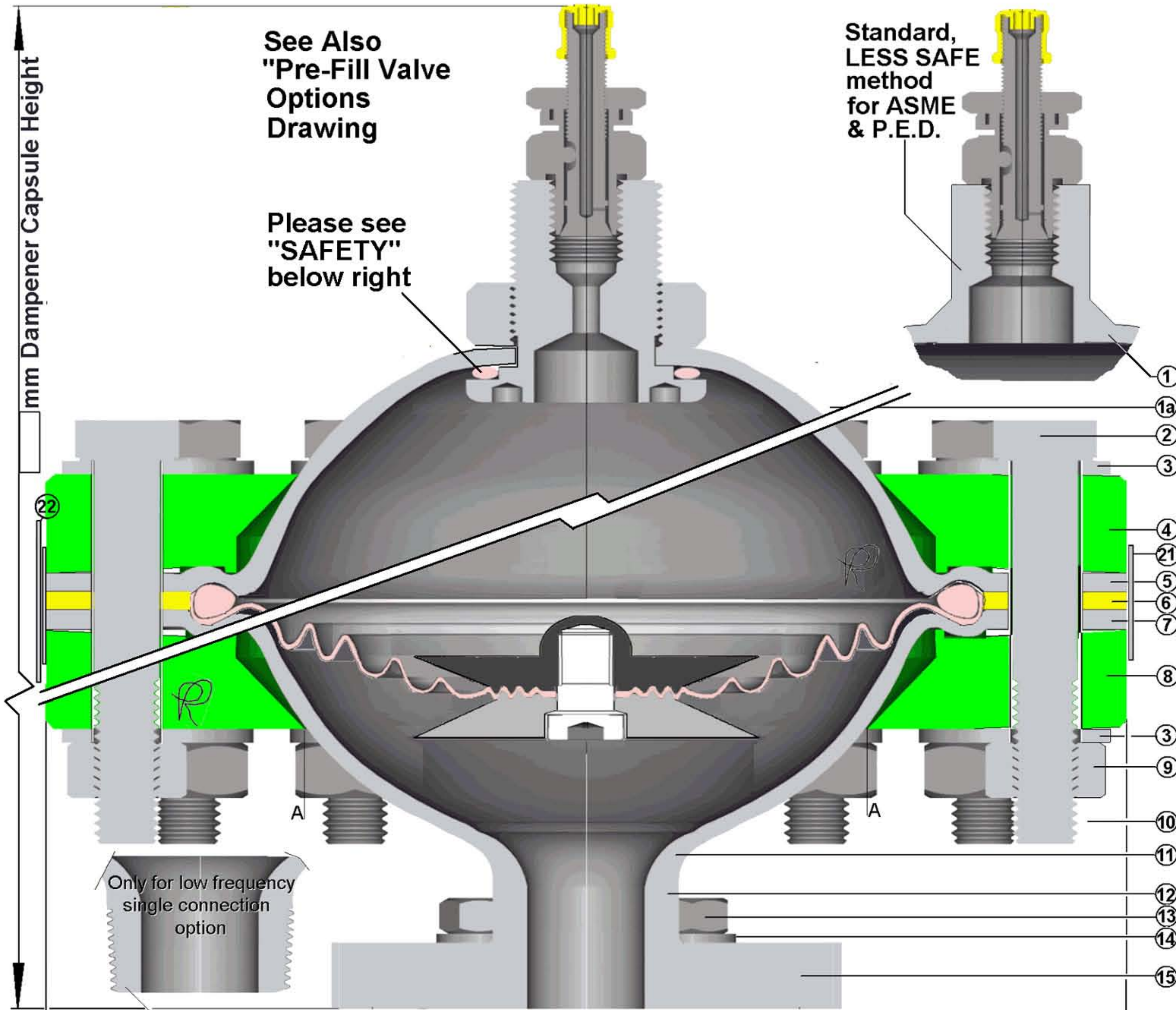

DECLARATION as required by PED Mandatory Essential Safety Requirement "ESR" state under design 2 at 2.1 the use of:

"SAFETY COEFFICIENTS" this can not be complied with because neither EN 5500 nor EN 13445 have any Safety Coefficients.

Accordingly:

It must be a fraud for any notified body to issue a certificate of conformity to ISO9001-2000 holders claiming any suitability for purpose from their quality system.

M. Packer, designer and "responsible party".

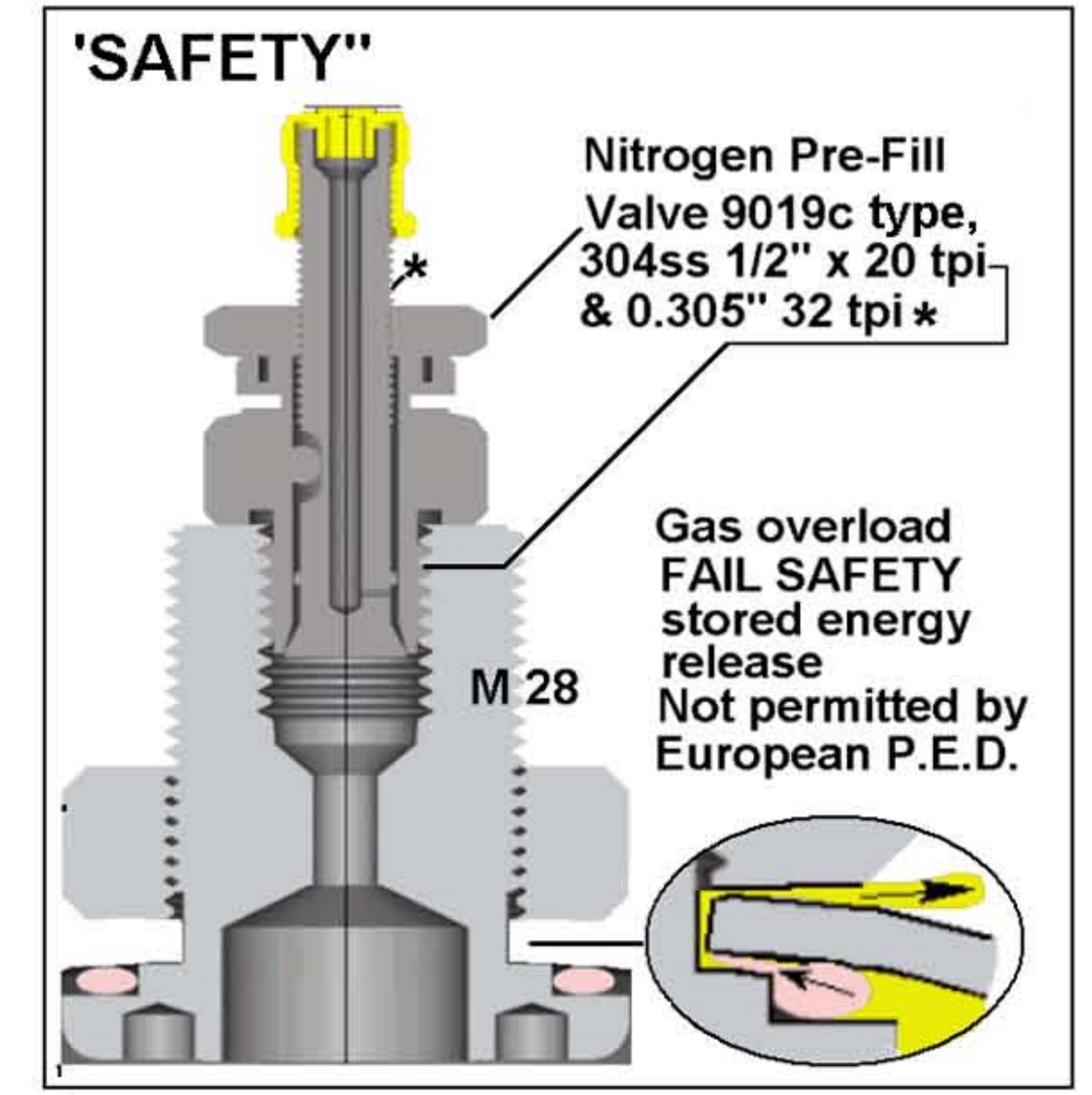
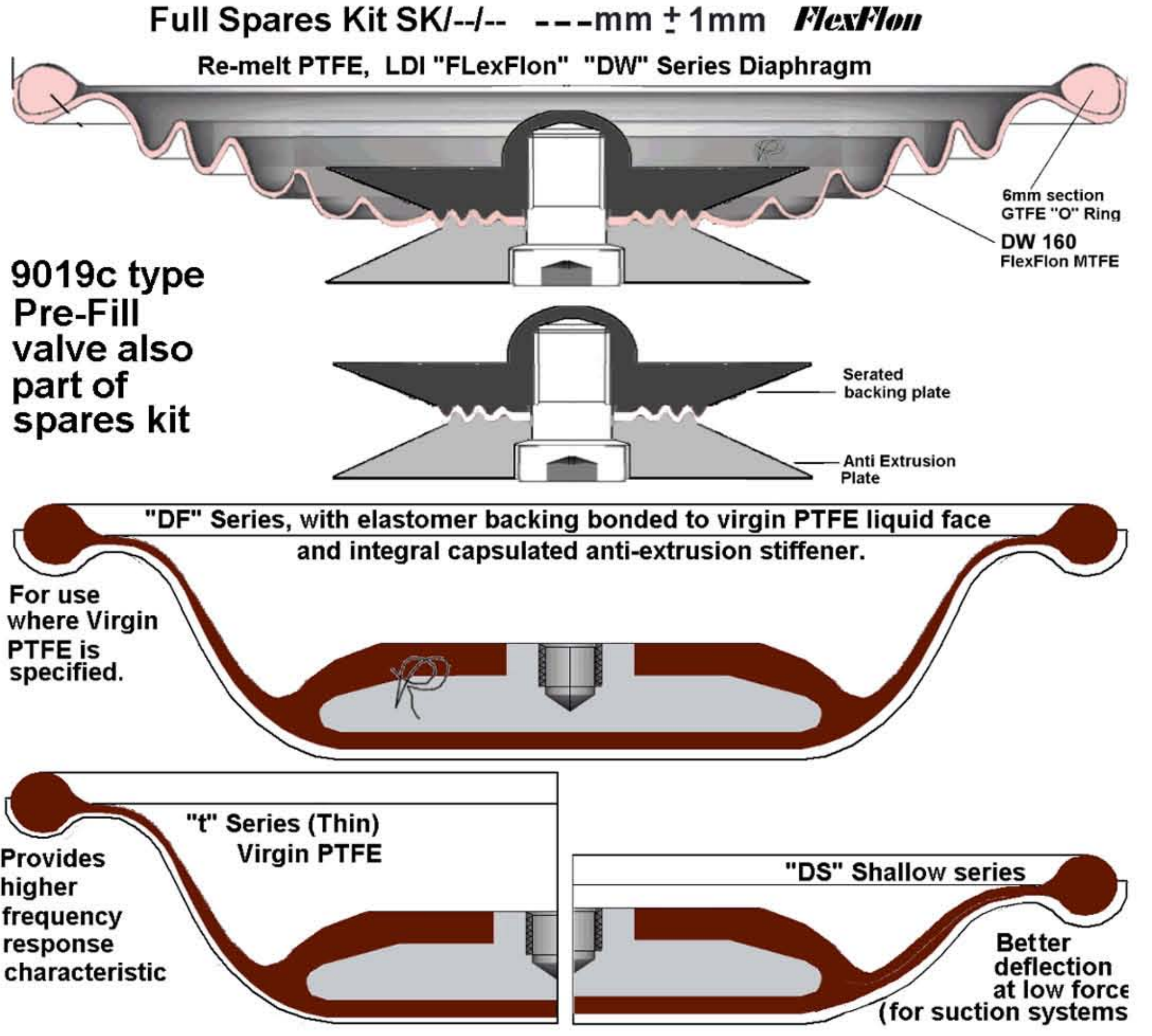

PulseGuard "Y-T" block, best flanging to system. In place of System "T", better flushing, & intercepts Pressure wave pulsation. For 37.5° butt weld only.

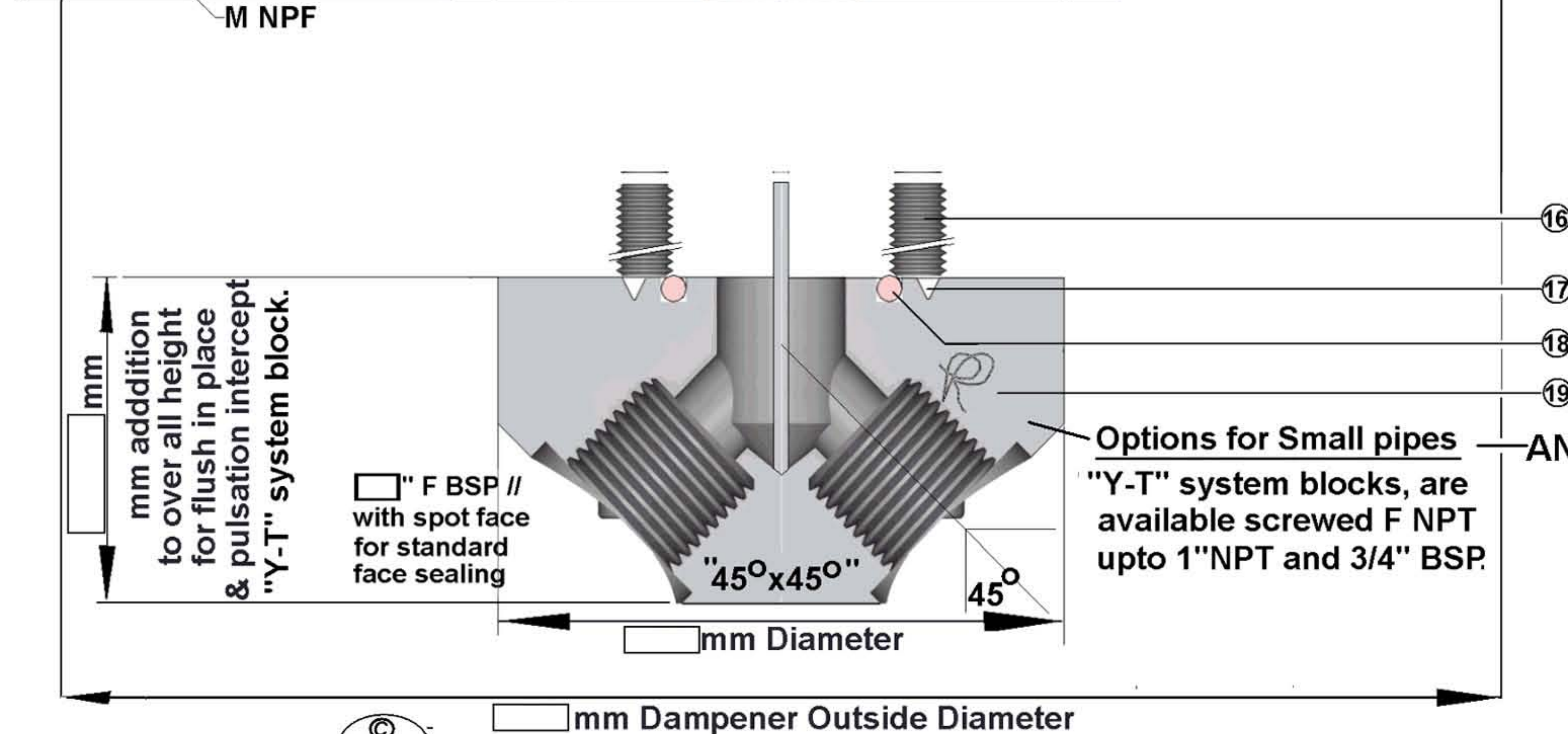
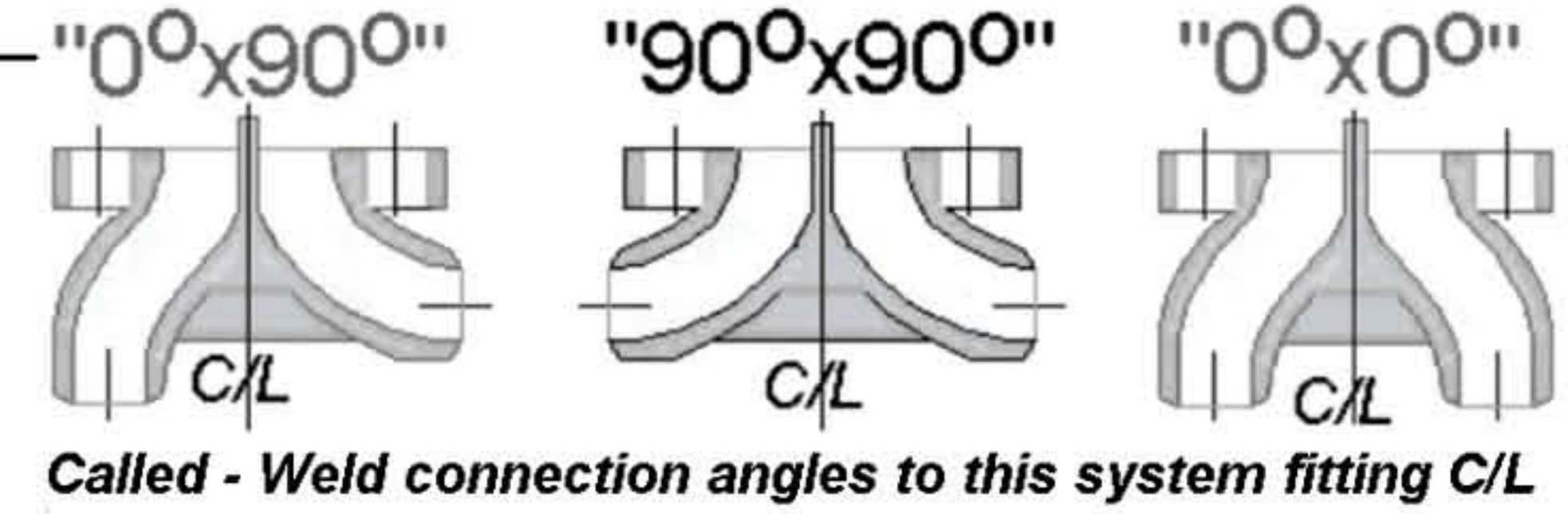

Item Nbr	Description / function	Internal "Heat/Cast No" PURCHASE No
22	Stainless Steel Data Plate.	
21	Stainless Steel split line Safety Band	
19	Piping base block, up to 4 ports.	
18	Face "O" seal	
17	Pressure relief escape groove.	
16	Socket head bolting, 4 equi-spaced	
15	Max connection OD to pass between A-A, 101 mm or 4"	
14	1/2" flat washers Can be 4 by 1/2" socket head bolts or 2.75" PCD	
13	Nuts for 4 by 1/2" socket heads on 2.625" PCD	
12	1" Schedule 160 pipe nozzle, Max ANSI flange 1/2" 600#, 3.75" OD or 3/4" 150# 3.875" OD	
11	Flared transition, 1" sch 160 to 4mm head, hole reinforcement	
10	3 places - All-thread on same Pitch Circle Diameter as boltings	
9	Nuts, 1 for each bolt, 3 per all-thread, provides 1 for mounting	
8	Support ring - liquid side, Contact outside the bolt circle.	
7	Flanged dishing, liquid side. Contact outside bolt circle.	
6	Spacer ring. Contact outside bolt circle.	
5	Flange of dishing, contact outside bolt circle	
4	Support ring - gas side, steel	
3	Large, flat washers.	
2	Bolts 9 places. Mounting, long "all-thread" 3 places.	
1a	N2 Side, Hydro-forged head w/ 28mm aperture	
1	Nitrogen Side, Hydro-forged head w/Prefill boss	

Scale : Please do not print without "MAINTAIN ASPECT RATIO" on, Use A3 paper on A3 paper Landscape 420mm wide

Part Nbr. / Drawing Ref. : Date th 200— Rev Nbr 1

SoG/ss/_i/_p/DW/_/"O"/316L-PTFE + PB _"x_" M NPT 316L

SHOCKGUARD <http://www.shockguard.co.uk>

SHOCKGUARD <http://www.shock-guard.com>

SHOCKGUARD www.waermeausdehnung.com

SHOCKGUARD www.schockabsorber.com

SHOCKGUARD www.shockguard.us

SHOCKGUARD www.shock-alleviators.co.uk

SHOCKGUARD www.surge-alleviators.com

SHOCKGUARD www.water-hammer.com

ShockGuard is the UK registered trade mark of ShockGuard US Div. ShockGuard is the USA registered trade mark of ShockGuard Ltd.

UK --44(0)161-480-9625 USA ---1910-270-2737

